

# Single arm davit system, type RhsL 14/3,5 for rescueboat and 16 person liferaft

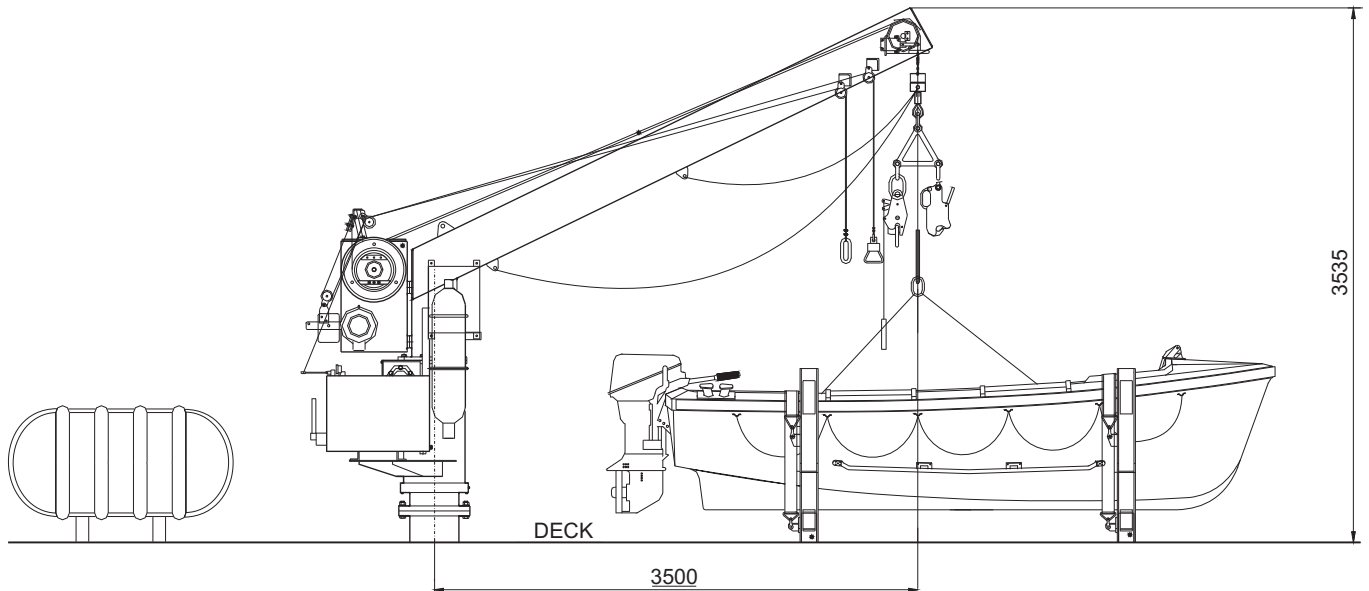

Scale 1:50

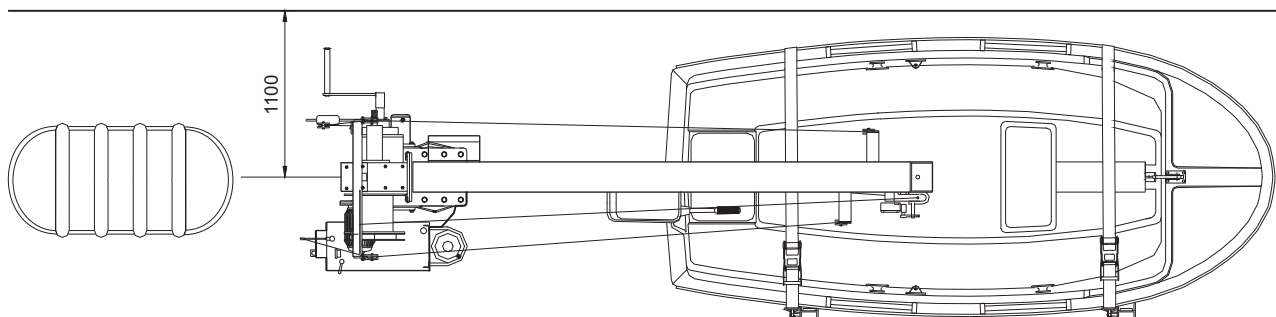

## Technical Data of the RhsL 14/3,5

### Davit Main Data

SWL .....	14 kN
Outreach .....	3,5 m
Hoisting Speed .....	18 m/min
Lowering speed .....	0,4 + (0,02 x H) m/s
Slewing Speed.....	abt 0,5 rpm
Voltage .....	380 / 440 V
Frequency .....	50 / 60 Hz
Total mass of davit system.....	1600 kg

### Rescueboat Main Data

Boat type.....	RB 400
Dimensions overall ....	4,00 x 1,80 x 0,70 m
Weight of boat with equipment .....	435 kg
Lowering / hoisting weight.....	885 kg

### Liferaft Main Data

16 persons davit launched type	
Weight of liferaft with equipment .....	185 kg
Lowering weight (max.) .....	1400 kg